

ROMSTAR

1942

Instruction Manual

Romstar, Inc.

3043 Kashiwa Street, Torrance, CA 90505

Phone: (213) 539-2744 Fax (213) 539-3626 Telex 182426

Licensed From CAPCOM

All Rights Reserved ©1985

Before You Get Started . . . Stop!

1. Does your **new game** package include all listed parts? (Is it complete?)
2. Is the game you have chosen to transform able to supply all the required voltages for the **new game**?
Note: Some games, (i.e. Ms. Pac Man, Galaxian, etc.) regulate their voltages on the main P.C.B. This makes the existing power supply inefficient. These games will require a change in power supply for your **new game**. Many game supply houses can offer you a switching regulated power supply for a relatively low cost.
3. Is the monitor configuration compatible? In most games it is rather difficult to change the monitor from a vertical mount to a horizontal mount. We recommend you choose a game cabinet with the same mount as your **new game** requires.
4. Do you have the necessary tools? (See the recommended tool list)

Caution

F.C.C. Regulation Compliance

The P.C. board cage supplied with this new game kit must be utilized and terminated to ground at the time of installation.

This is to avoid radio frequency radiation and comply with the limits for a class "A" computing device pursuant to sub-part "J" of part 15 of F.C.C. rules, which are designed to provide reasonable protection against interference when operated in a commercial environment.

Operation of this equipment in a residential area is likely to cause interference — in which case, the user at his own expense, will be required to take whatever measures may be required to correct the interference.

Installing and Servicing Your



New Game Package

Table of Contents

New Game Package Contents	3
Power and Monitor Requirements	3
Recommended Tools and Supplies	4
Dip Switch Tables	4
Game Operation	6
Installation Procedures	7
Diagnostics and Adjustments	12
Control Panel Positioning	16
Main Harness Connections	inside back cover

1942

NEW GAME PACKAGE CONTENTS

1 Main Printed Circuit Board (PCB)	1 Marquee
1 PCB Cage (FCC Required)	1 Control Panel Overlay
1 Set Legs, Bolts, & Spacers	1 Plex Control Cover
1 Connecting Wire Harness	1 Set Side Graphics
1 Eight-Way Joystick	1 Set Play Instructions & Function Labels
4 Player Button Assemblies	1 Service and Installation Manual

Note: Replacement accessories available through your exclusive **Romstar** distributor.

POWER REQUIREMENTS		MONITOR REQUIREMENTS
+5 VDC +12 VDC	5 amp 1 amp	Vertical Mount Raster Scan Negative Composite Sync

Recommended Tools and Supplies

ROMSTAR **new game** package.
 Phillips and Slot Screwdrivers
 Socket Set
 Enthusiastic Attitude
 Wire Cutters and Strippers
 Pliers or Channel Locks
 Planning and Careful Thought
 Electric Drill
 3/32" • 1/4" • 7/16" Drill Bits
 1/4" Plex Bit
 1-3/16" Chassis or Sheet Metal Punch
 1 1/4" Plex Hole Saw
 Glass of Water and a Snack
 Small File
 Razor Knife and Sharp Blades
 Straight Edge
 Patience
 Common Sense

Painting Supplies (if you do your own painting)
 Paint Brush and Paint (don't forget the primer)
 Paint Roller and Pan
 Sand Paper
 Putty Knife and Wood Putty
 A Good Night's Sleep
 Staple Gun and Staples
 Soldering Iron and 60/40 **Resin Core**
 Solder
 Vacuum Cleaner
 Assorted Fastening Hardware
 Shrink Tubing: 3/32" • 1/8" • 3/16"
 Masking Tape
 3 1/2" OR 4" Wire Ties
 Spray Window Cleaner and Rags
 (baby diapers work GREAT!)

Dip Switch Tables

Optimize Your Profits

Thorough Research shows that two and a half minute games both satisfy players and also keep the quarters flowing.

If games aren't running about two and a half minutes long, then collections probably aren't at their peak. You'll want to tailor your game to your location. The trick is to adjust a few DIP switches. (See the chart in this book.) It's easy!

Game Adjustments

Use the Dip-Switch Banks. Game adjustments are made with DIP-switch bank A and DIP-switch bank B on the CPU board. Select your options from the **Dip-Switch Table** in this book. Then turn the game off.

For each new setting, you'll have to change the position of one to three switches on a single DIP-switch bank. Use a pen or small screwdriver to operate the switches. Now for the multiple-choice section. **Choose one or more:**

- For a shorter game, **increase the scores** at which players achieve bonus points.
- For a longer game, **reduce these scores.** (Use DIP-switch bank A, switches 3 and 4.)
- For a shorter game, **raise the difficulty level.** For a longer game, **reduce it.** (Use DIP-switch bank B, switches 2 and 3.)

Customize game pricing to suit your location. (Use DIP-switch bank A, switches 6 through 8.)

Game Operation

- **Buy-In Feature.** After completing a game, players are invited to “buy in” or continue where they left off. Continued games are more challenging than original games. So continued games tend to involve skilled players at the level they prefer **and to increase collections.** To buy in, a player inserts his next coin while “CONTINUE GAME” appears on the screen. Then he holds the fire button and pushes start.

Playing Tips

- **Points** depend on the percentage of enemy planes destroyed. (Bonus points will be different if a player’s plane is on an aircraft carrier.)

Example: 90% 10,000 Points

- **Loops.** In any wave the player can only loop three times (number of loops is displayed on the bottom of the screen). The number of loops adds bonus points when the player returns his plane to the aircraft carrier.

Example: 1 Loop 1,000 Points

- **Extra Power.** If the player destroys all enemy planes of one color, POW appears on the screen. Touching the Power Unit gives the player an advantage that depends on the color of planes shot down . . .

Green Planes Player’s plane becomes a 4-shooter

Yellow Planes One loop is added

Orange Planes Enemy plane stops shooting for 15 seconds

White Planes All enemy planes are destroyed

Gray Planes Shield is added to player’s plane

Black Planes Player’s squadron gains a plane

Red Planes Points

- When a player destroys a complete red-enemy squadron (**all planes of one color**), POW appears on the screen.
- When a player destroys the heavy bomber, the bomber wave ends.
- At the end of the game the screen indicates the number of enemy planes shot down and the percentage destroyed.
- If a player destroys all enemy planes of the red color, POW appears on the screen. However, if an enemy plane shoots down the player’s aircraft, the enemy squadron under attack (all planes of one color) return.

Installation Procedures

Something To Think About

Your final product will be a **new game**.

You have made a wise decision to transform a game that has seen better days in the all important cash box into a **new game**. This is by far the most cost effective alternative to maximize the return of your initial investment. All you provide is the cabinet with a power supply and a monitor. Oh yes, you will need a touch of elbow grease. And that's it! We provide the rest. The end result is . . . a **new game** at a very low cost.

Fact: Spend a little time on the cabinet's appearance (i.e. marquee, control panel and cabinet graphics). With a little paint, some wood putty and new lights, you will raise the profits of any game. . . especially with the introduction of a **new game** package.

The **new game** look should always apply to the inside of your game as well as the outside. A few wire ties and shrink tubing on your harness; some fastening hardware on your subassemblies and a sweep with the ol' vacuum cleaner will ensure that unnecessary *glitches* do not occur.

Remember: You are creating a **new game** .

If you have any questions or just need some advice on any of your **new game** transformations, don't hesitate in giving a member of our technical staff a call.

Let's Get Our Hands Dirty

Preparing the Original Game for the New Game

Remove the following:

- | | |
|------------------------|------------------|
| 1. Main logic board(s) | 4. Monitor Bezel |
| 2. Control panel | 5. Marquee |
| 3. Monitor plexiglass | 6. Graphics |

I would recommend painting your cabinet to give it a fresh new look. (If it is geographically inconvenient to make use of our facilities, you may consider having an auto body shop take care of your painting needs.)

If your cabinet has wood grain sides; remove old graphics and adhesive (adhesive may be removed with **lacquer** thinner.

If you intend to use your original plexiglass, be sure it is in mint condition or it should be replaced.

Thoroughly clean out your cabinet.

Time To Install Your New Goodies

Before You Start . . . Remember DO NOT Do This Work With The Power On!

Logic P.C.B. Cage

Mount the logic cage securely (away from power supply).

- A Mark and drill pilot holes (3/32").
- B Place the logic cage (bottom) over the holes and secure it with the supplied wood screws.
- C Install the P.C.B. into the logic cage. Use feet and spacers supplied and adjust them so that the screws will go through the slots into the cage bottom.

Note: Leave the cage cover off until you have attached the entire wire harness and have tested the game for proper operation.

Wire Harness

Attach the wire harness connector to the main logic board. **CAUTION:** Sometimes the connector is not keyed and it is very easy to install it reversed on the logic board. Even if it is keyed, always **triple check** to be sure the wire inputs were connected correctly to the connector and the connector to the logic board.

Connecting the Wire Harness to the Existing Wires

When you hook up the control panel, power supply, monitor or other subassemblies that remain in the game cabinet to your new wire harness, try and use their existing secondary connectors.

1. Cut the original wire approximately three inches from the original connector. Strip off about one half inch of insulation.
2. Solder the new wire designated for that position to the original wire you just stripped.

Warning: DO NOT JUST TIE THE WIRES TOGETHER. THIS CAN CAUSE NAGGING INTERMITTENT PROBLEMS THROUGH LOOSE CONNECTIONS OR OXIDATION OR BOTH. **Always take the time to do it right.**

3. Melt shrink tubing around all your in-line wire connections. Do not use electrical tape. Tape could unravel over a period of time due to the cabinet heat and cause you a great deal of trouble.
4. Use wire tie wraps, and secure the cable to the cabinet whenever it seems necessary. Remember this is a **new game**, not a sloppy conversion.

Power Wires

1. Connect the wires that are designated for your power supply. You will need a supply of +5V, +12V & ground. Your **new game** package may not require all of the voltages that were used in the original game. Tie off any unused wires.
2. You will notice that you probably have more than one wire for each voltage. It is a good idea to use all wires supplied (double up if it is necessary). This will help to ensure that you don't overload the edge connector pins and cause them to "burn".

Monitor Wires

You will be connecting the wires designated for the RED, GREEN & BLUE video guns along with the SYNC & GROUND wires.

NOTE . . . CONCERNING SYNC:

Your **new game** only calls for one sync wire connection, this is called **composite sync** (horizontal and vertical tied together). This composite sync is also **negative**. Most monitors have supply positions for both negative and positive sync. You can check your monitor manual or call our technical department for assistance.

Speaker Wires

Find the two wires that are designated for the speaker and hook 'em on up.

Coin Door Wires

1. Connect the designated wires to the coin switches and meter.
2. You can connect your door lamps to the unused –5V power supply. Some games have separate power outputs for the coin door lamps.
3. Be sure to clean and lubricate your old coin mechanisms. Keep the money coming in.

GUESS WHAT?

You are almost done with the electrical connections of your **new game**. All you have left is the control panel wiring. But we are going to hold off on that for right now. We have a few other things we need to do first. So why don't you go ahead and get yourself a drink of water and stretch your legs. When you return, we can take a fresh look at your progress and then move forward.

Smoke Test

What Test?

Don't worry. All this means is that you are ready to apply power to the system for the first time and you pray that there will be no smoke from a simple oversight.

You are just about ready to power up the logic board. But first we need to recheck your work.

1. Carefully inspect the game for loose power wires, exposed connections and extra fastening hardware.
2. Make sure the logic board, board cage, monitor and power supply are securely fastened in place.
3. **Double check** the connectors to be sure they are wired and connected properly.
4. Set the dip switches on the logic board to the factory recommendations. (Refer to page 5.) Also, be sure you set the dip switches for "DEMO WITH SOUND". This will enable you to hear as well as see that your new P.C.B. is functional.

Time to Apply Power:

1. Look and smell for smoke. (TURN OFF IMMEDIATELY IF ANY IS NOTICED)
2. Listen for game sounds.

If after one minute you have not heard any sounds:

- A) Check for proper dip switch settings.
- B) Adjust volume control and check speaker connections.
- C) Check the +12V power supply to the logic board.

NOTE: If you do get sounds, but they are a little fuzzy, switch the wires around on the speaker.

3. How is the monitor image?

A) Is the picture in sync?

If your picture has the top and bottom halves of the screen reversed and it will not stop rolling, change your sync polarity on the monitor. (Positive to negative).

If your monitor does not have dual polarity positions for sync, then you will need to reverse the sync yourself by installing a simple one I.C. circuit between the logic board and the monitor. (The following illustration shows a hookup for both **composite** and **separate** syncs.

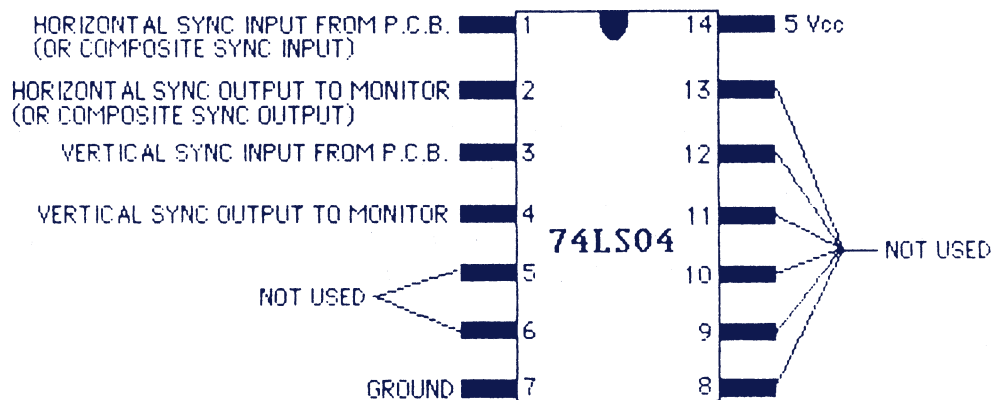

B) Now how's your picture?

- Is it centered?
- Is it too bright or dim?
- Is it in focus?

Check your monitor manual for these adjustments. If your screen looks "off", then your **new game** transformation may have been in vain. So let's take the time to make the monitor look great.

C) Is the picture upside-down?

Dip switch 4 on switch bank "B" should solve your problems.

Control Panel Assembly

1. Remove the buttons, joysticks and wire harness and put them aside for now. Do not remove the original panel overlay until the new holes have been drilled.
2. Mark positions on the panel for the new holes as specified on page 16.

ROMSTAR supplies a clear 1/8" thick piece of plexiglass with every **new game** package to cover the control panel. We feel that your **new game** investment is well worth protecting . . . and the control panel is the first place to show wear and tear.

 - You will need to cut this piece to size. Use the control panel as a template.
 - Use a razor knife to score the plexiglass **deeply**. Then use a pair of pliers to break away the extra plexiglass.
3. Now drill the holes in your panel that you have marked off for the *buttons, joystick* and *bolts*.

Hint: For best results, use a chassis or sheet metal punch for button holes.
4. Drill the same holes on your plexiglass panel protector. Once again use your panel as a template.

Hint: To avoid chipping while you are drilling the holes, place the plexiglass securely on a soft wood surface and use a plexiglass drill bit and hole cutter.
5. The holes are now all cut. Smooth them out on your panel and plexiglass with a fine toothed file.
6. Remove the original graphics overlay from the panel. Clean up the panel and install your **ROMSTAR** graphics.

Make It Easier: Peel the top half of the protective backing off of your graphics. Start from the center and smooth out your overlay. Make sure you have about an inch extra coming off the top. *No bubbles please*. Now peel off the bottom half and do the same as you did for the top.
7. Adhere the instruction and function labels.
8. Install the Plex Control Cover over your completed **new game** panel.

Note: Be sure to bolt the plexiglass securely to the panel.
9. Mount the joystick and the buttons to the panel and wire them up. (Use the existing Panel wiring if possible)

Marquee Installation

Using the original marquee as a template, Center your **new game** marquee graphics and score the new marquee deeply to fit the cabinet. Break off the excess with pliers.

Be sure the light behind the marquee works. Everything should **always work** on a new game.

Take your time ... Don't forget this is going to be a **new game**.

Side Graphic Installation

1. Be sure sides of game are clean and free of old adhesive, dust, etc.
2. Mark position of decal with erasable pen or pencil (centered on upper half of cabinet).
3. Peel off top 1/4 of decal backing and apply to cabinet with a smoothing motion (use a soft rag). Continue peeling off backing and smoothing.
4. Remove any small bubbles with a pin or razor blade (pop them!)

Finishing Touches

1. Check the game inside and out for any imperfections. Secure any loose wiring or fastening hardware.
2. Make sure the coin door is tight and the coin mechs are well adjusted. A game is no good to anybody if you can't get a coin into it.
3. Once again go over every step of this **new game** transformation in your mind. Be sure everything is correct and to your liking.
4. Power up the game.
 - A. Check all the coin switches. (Does the coin meter work?)
 - B. Play your **new game** .
 - Are all the player controls working?
 - Are the game sounds present?
 - Is the volume level proper?
 - Are the dip switches set properly?

Well, that's about it. Good Luck.

Diagnostics and Adjustments

Your game includes a **Diagnostic Mode** that checks operation and helps you make adjustments to insure optimum performance.

Entering Diagnostic Mode. Turn the game off. Use a pen or small screwdriver to turn on DIP-switch 5 of DIP-switch bank B on the CPU board. The machine will start in the **Diagnostic Mode** when you turn it on. **Diagnostic Mode** consists of eleven independent tests.

RAM CHECK					
		ADDR	WR	RD	LOC
W-RAM 1	=	- OK -	* *	* *	N09
W-RAM 2	=	- OK -	* *	* *	N10
C-RAM	=	- OK -	* *	* *	D02
S-RAM	=	- OK -	* *	* *	A09

Lever = Next

Figure 1. **RAM Test**

1. Ram Test

The RAMs are automatically checked before the other ten tests start. When a RAM error is detected, the display identifies the bad RAM with NG instead of OK. **(Of course power, buss or clock problems may cause a good RAM to appear bad.)** Tests can't proceed if all RAMs don't check OK. After the RAM check is over, move the joystick to display the test menu.

```

                                TEST MENU
01  INPUT
02  OUTPUT
03  HARD COLOR
04  SOFT COLOR: CHAR
05  SOFT COLOR: SCROLL
06  DOT CROSS HATCH
07  CHAR
08  SCROLL
09  OBJECT
10  SOUND

F: EXEC

```

Figure 2. **Diagnostic Menu**

Test Method

The next ten tests are performed using the joystick lever and the FIRE (F) button. A status message appears at the bottom of the screen . . .

F: FIRE Button

JOYSTICK . . .

RT: To increase numbers displayed on the screen, move right.

LT: To decrease numbers displayed on the screen, move left.

EXEC: A test is being executed.

END: The test is concluded.

LEVER & F: You're using the joystick and FIRE button simultaneously.

The **Red Symbol** is the cursor. Use the joystick to move the cursor beside the desired test. Now push FIRE.

2. Input Test

Tests 2 and 3 help you evaluate the game's I-O port. Test 2 lets you see if switch operation is being recognized by the computer. When you press a switch, a 1 should be displayed (among the zeros on the right half of the INPUT TEST screen). When that switch is released, a 0 replaces the 1. Similarly when a DIP switch is ON, a 1 should be displayed and when OFF, 0 should appear.

3. Output Test

Check the outputs. Move the cursor and set any bit on or off by pushing FIRE. Look for stuck bits. (D1 and D0 of address C806 can't be changed since they're permanently set to 1.)

4. Hard Color (Monitor) Test

"Hard color" refers to your game's hardware. Of course your game's hardware for displaying colors is the **monitor**. That's what this test helps you check. Colors are displayed. Do you like what you see? If so, go ahead to the next test. Otherwise it's time to adjust your monitor's screen, black-level, cathode-drive and cutoff controls. You can use test 7 (crosshatch pattern) for the rest of your monitor-setup chores.

5. Soft Color (Character) Test

The soft (software) color test examines your video RAMs by displaying characters. Missing or incorrect characters may indicate a bad video RAM.

Other Chips that share the same address or data buss as your video RAMs may also cause character malfunctions. In addition, bad clock signals that normally **enable** (CE, WE, etc.) **strobe** or **select** (CS1, RAS, CAS, etc.) RAM functions might cause a good RAM chip to malfunction.

Use your Logic Probe and check the neighborhood of the suspected RAM for missing logic pulses.

6. Soft Color: Scroll (ROM) Test

This test displays the scrolling colors. Check for missing or incorrect colors. If you find a malfunction, suspect a bad ROM (but don't forget to check buss and clock signals used by the ROM).

7. Crosshatch Screen

The crosshatch screen helps you to optimize your monitor's purity, linearity, focus, and convergence. Picture size and position can also be tweaked while you're displaying this screen. Push FIRE for the next test.

8. Character Test

This test displays the game's character patterns. Check for missing characters. If you find a malfunction, suspect a bad ROM (but don't forget to check buss and clock signals used by the ROM).

9. Scroll Test

This test displays the game's scrolling patterns. If any pattern is missing, suspect a bad ROM (but don't forget to check buss and clock signals used by the ROM).

10. Object Test

This test displays the object patterns used in this machine. If any pattern is missing, suspect a bad ROM (but don't forget to check buss and clock signals used by the ROM).

11. Sound Test

You can make adjustments to the sound effects with this test. Also, if your sound section is malfunctioning, this test helps you locate the problem. Choose options 00 through 1F by moving the joystick. Listen for incorrect missing or duplicated sounds.

- A. If all sounds are incorrect, the problem could be a bad RAM or ROM.
- B. If all sounds are missing, the problem could be analog. . .
 1. leaky electrolytics that normally couple audio signals to the speaker;
 2. a bad power-amplifier chip (last IC before the speaker);
 3. AC or incorrect DC voltages on amplifier-power pins
- C. If all sounds are missing, the problem could also be digital. . .
 1. suspect a bad D-to-A converter,
 2. a bad crystal,
 3. a bad sound-microprocessor,
 4. or a bad chip (buffer, PIA, etc.) that handles data or addresses.
- D. If only a few sounds are missing or duplicated, suspect a digital problem such as open or shorted sound-select (address) lines.

Here are your SOUND-TEST options. . .

00	Disables sound effect 01, 0F, 11, 12, 15-19 and 1A	10	Music OFF
01	B29 propeller ON (Use FIRE to enable)	11	Background music
02	B29 explosion	12	Starting music
03	Ricocheting enemy bullets	13	Bonus wave music (at beginning of wave)
04	Enemy plane exploding	14	Background music when heavy bomber appears
05	Player's firing sound	15	Bonus-wave clearing music
06	Player's circling sound	16	Game-over music
07	Sound when taking a POW	17	6th-place and under music
08	Sound when player receives a bonus plane	18	Top-score music
09	Typewriter	19	2nd to 5th-place music
0A	Coin-insert sound	1A	Starting music when heavy bomber appears
0B	B29 propeller OFF	1B	Typewriter ringing-sound
0C	Player's propeller OFF	1C	Unused
0D	Player's plane taking off	1D	Unused
0E	Player's plane landing	1E	Unused
0F	Player's propeller ON (Use FIRE to enable)	1F	Unused

Entering Game-Over Mode

When you desire to end the **Test Mode**, turn the game off. Now set DIP-switch 5 of DIP-switch bank B to OFF and power up.

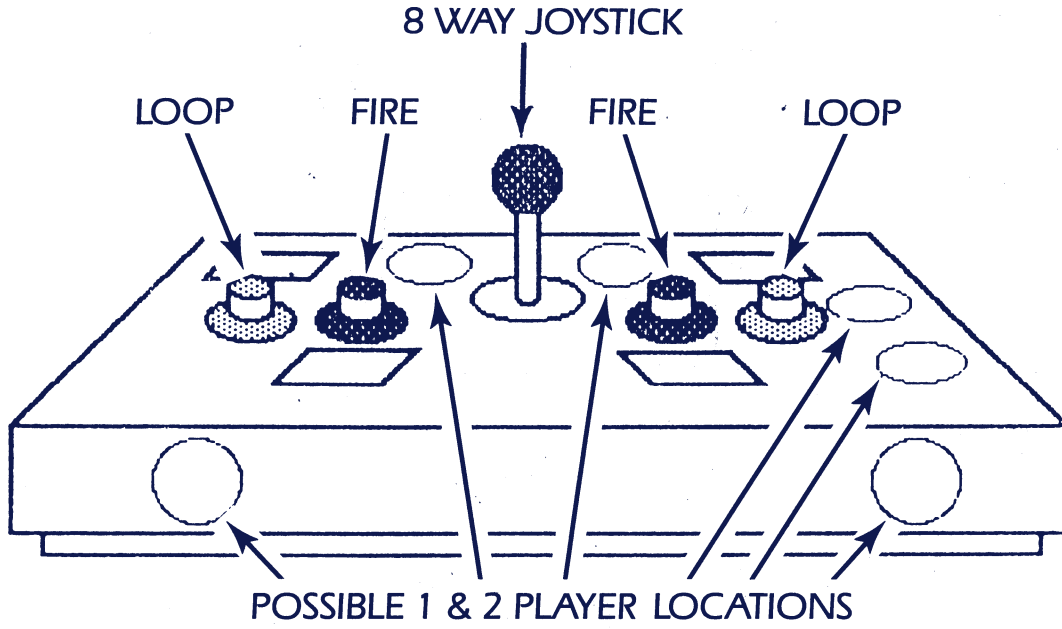

Control Panel Positions

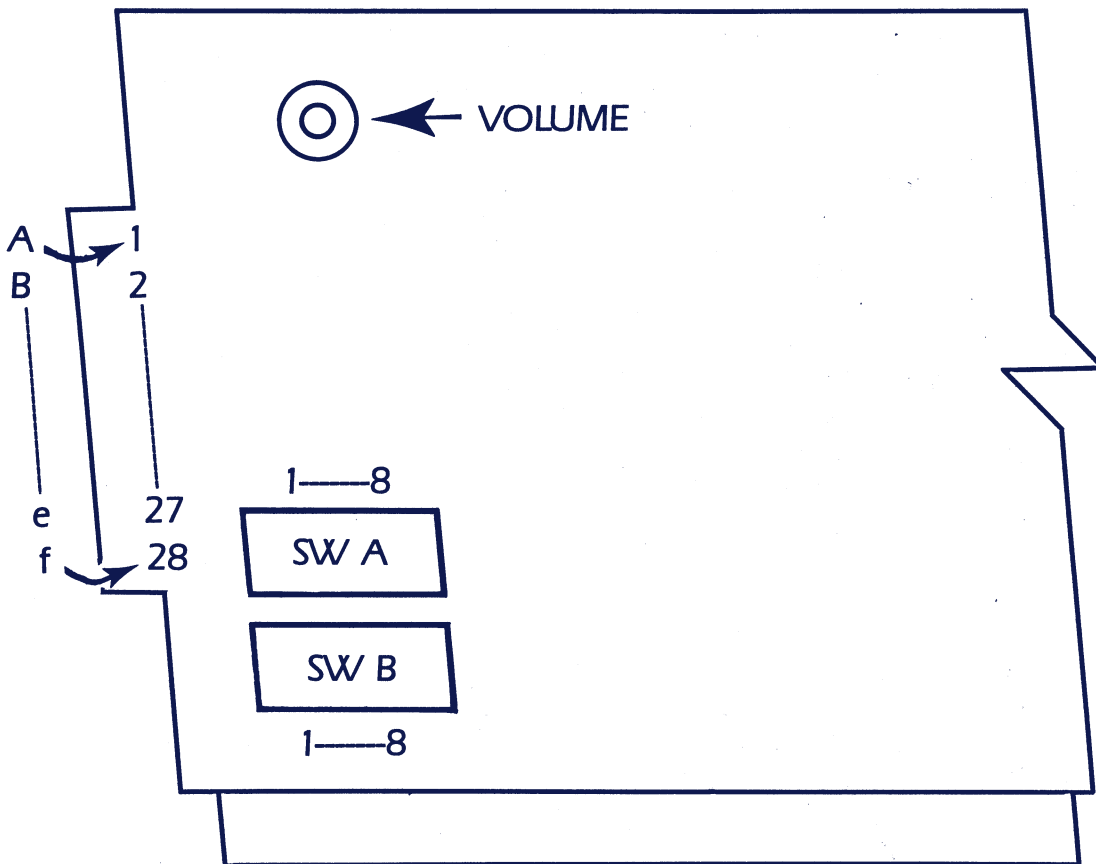

PCB Layout

1942 MAIN HARNESS CONNECTIONS

Solder Side				Parts Side	
Black	GND	A	1	GND	Black
Red	+5V	B	2	+5V	Red
Yellow	+12V	C	3	+12V	Yellow
Black	GND	D	4	GND	Black
Black	(-) Speaker	E	5	Speaker (-)	Black
White	(+) Speaker	F	6	Speaker (+)	White
Black	(-) Coin Counter	H	7	Coin Counter (+)	Gray
---	Key	J	8	Key Key	---
Brown	Shot 1 P	K	9	UP 1 P	Brown
Red	Down 1 P	L	10	Left 1 P	Red
Orange	Right 1 P	M	11	GND 1 P	Black
Yellow	Shot 2 P	N	12	Up 2 P	Orange
Green	Down 2 P	P	13	Left 2 P	Yellow
Blue	Right 2 P	R	14	GND 2 P	Black
Violet	2 Player Start	S	15	GND	Black
Gray	1 Player Start	T	16	GND	Black
White	Coin Switch	U	17	GND	Black
White	Service Switch	V	18	GND	Black
	not used	W	19	1 P Loop	Green
	not used	X	20	2 P Loop	Blue
	not used	Y	21	Grid (Video)	Black
Gray	Sync	Z	22	Red (Video)	Red
Green	(Video) Green	a	23	Blue (Video)	Blue
	not used	b	24	not used	
	not used	c	25	not used	
	not used	d	26	not used	
Red	+5V	e	27		
Black	GND	f	28	GND	Black

2 P Connections for Cocktail Only (Except 2 P Start)

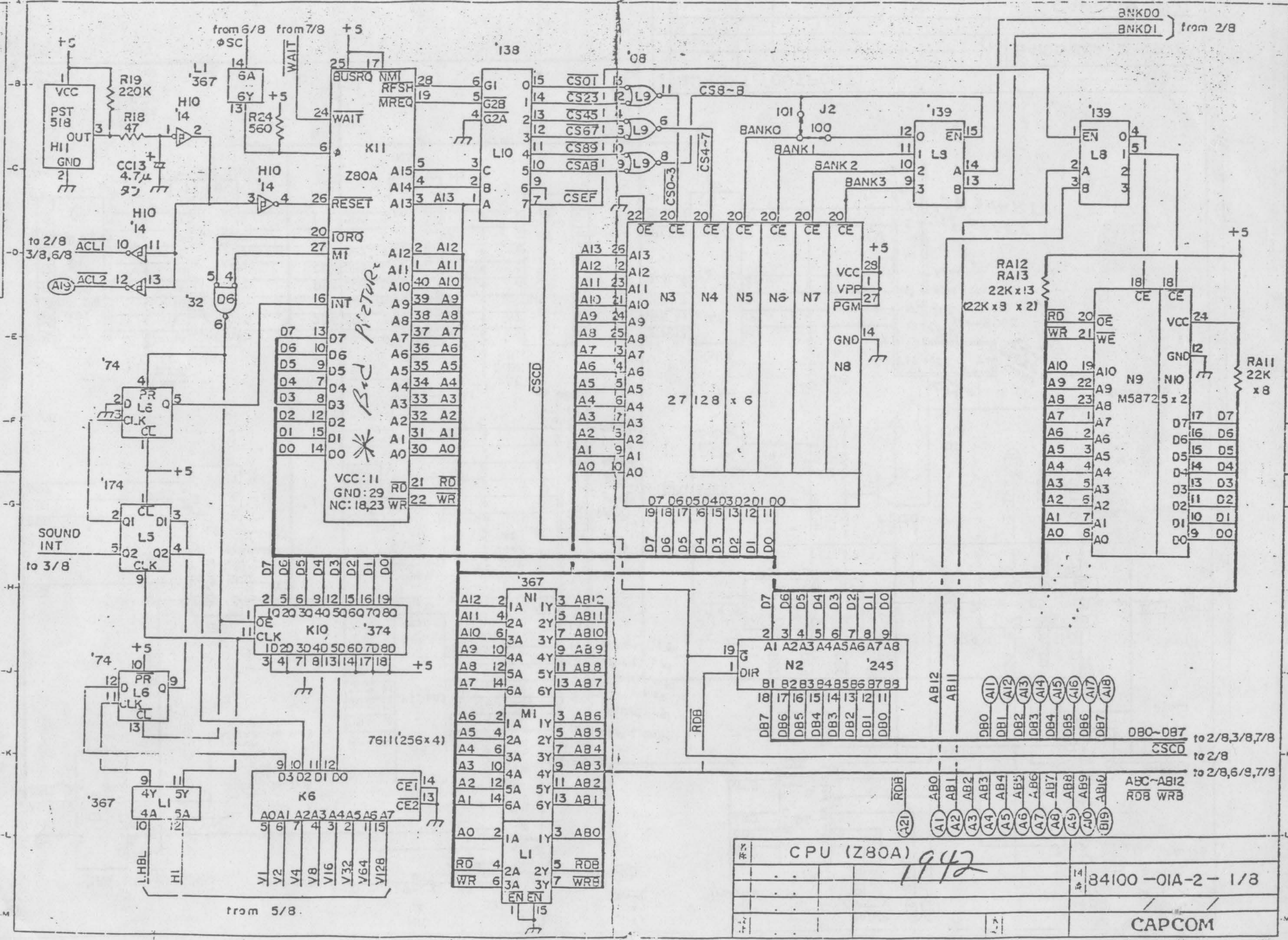

CPU (Z80A)		1942
		34100-01A-2-1/8
		CAPCOM

Bad picture

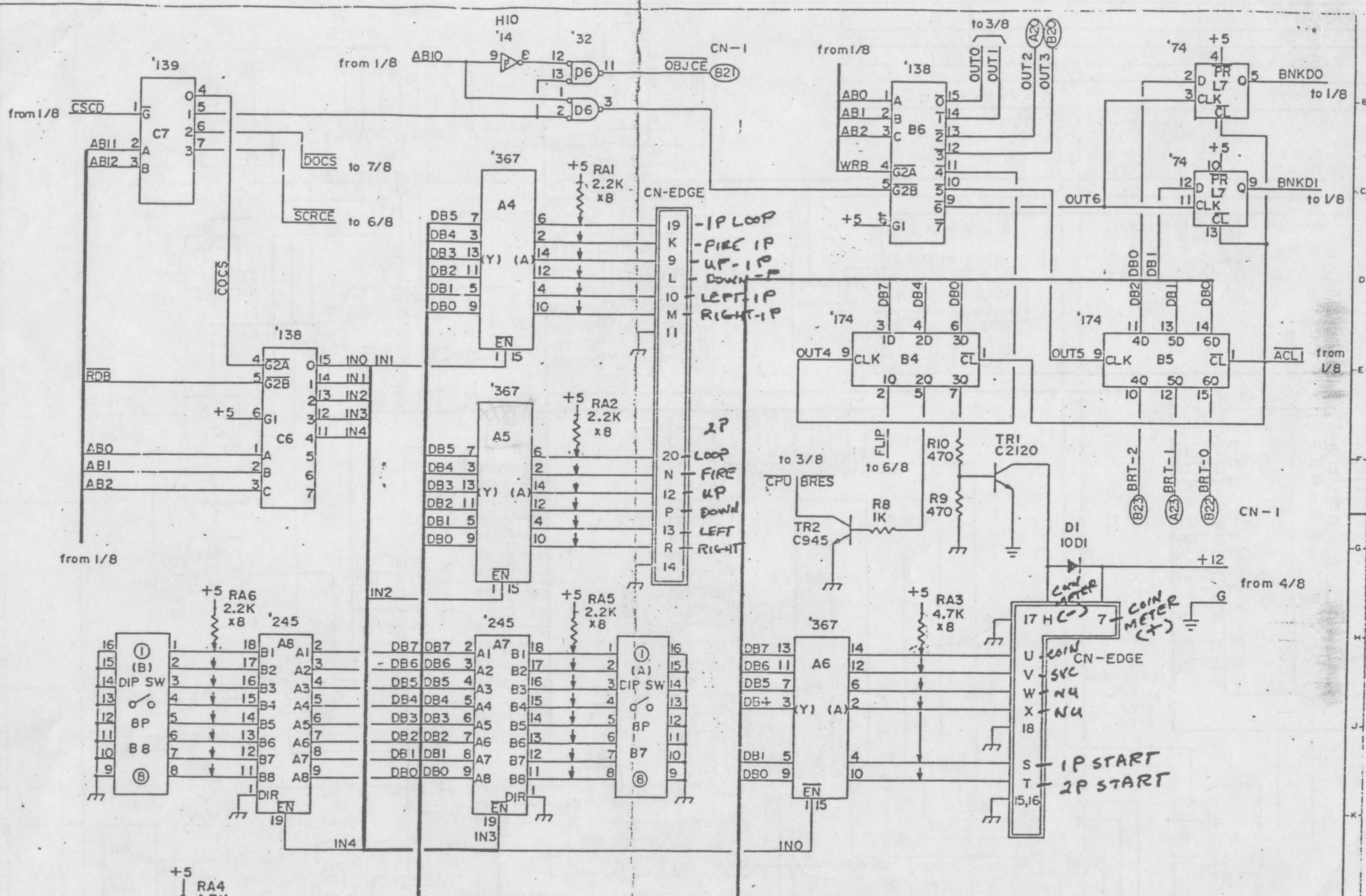

Pin	INPUT	OUTPUT
14		84100-01A-2-2/8
		CAPCOM

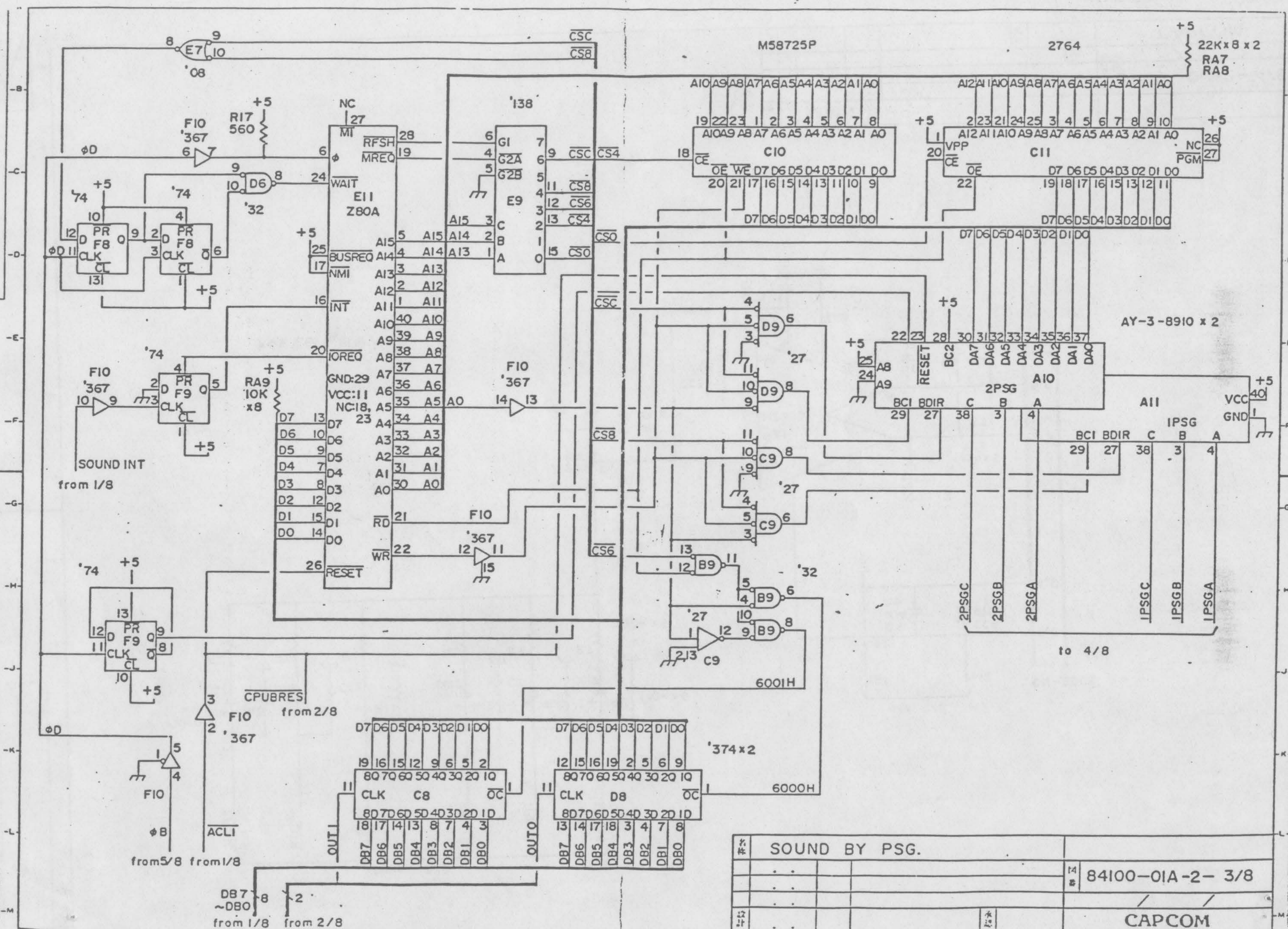

SOUND BY PSG.	
Part No.	84100-01A-2-3/8
Rev.	
Manufacturer	CAPCOM

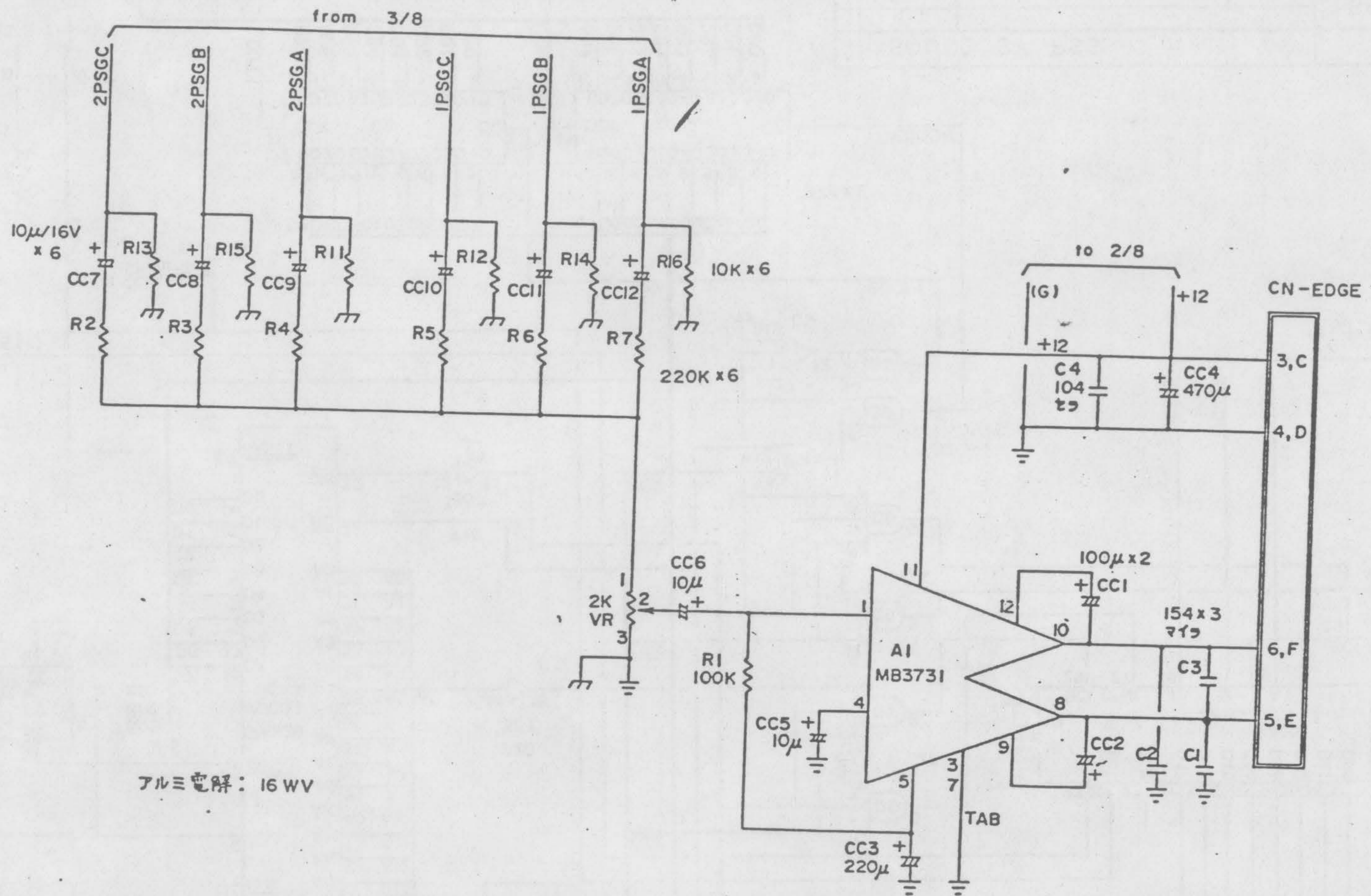

アルミ電解: 16 WV

名称	MAIN AMP.		図番
			84100-01A-2-4/8
設計		承認	CAPCOM

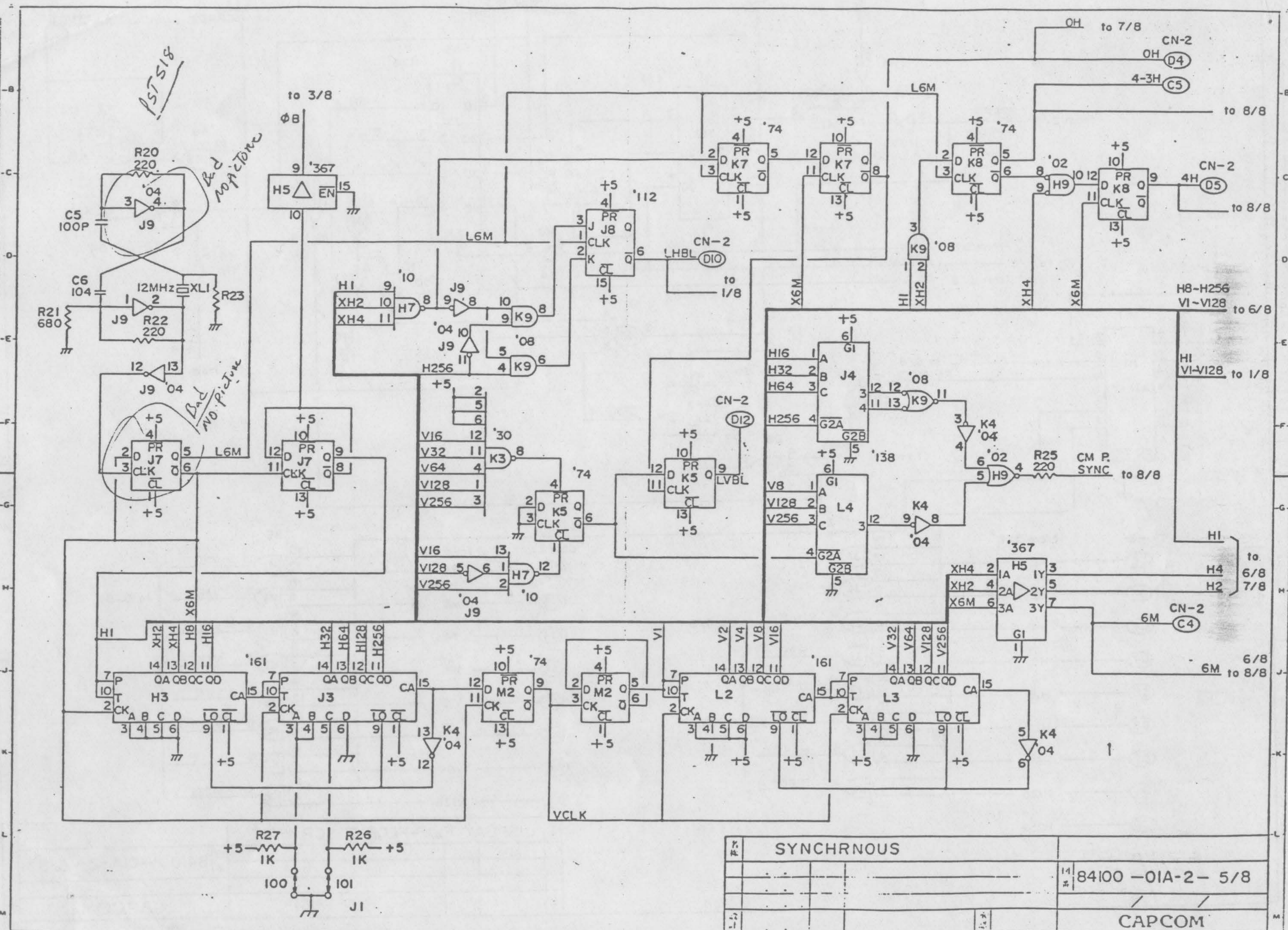

SYNCHRONOUS	
14	84100 -01A-2- 5/8
CAPCOM	

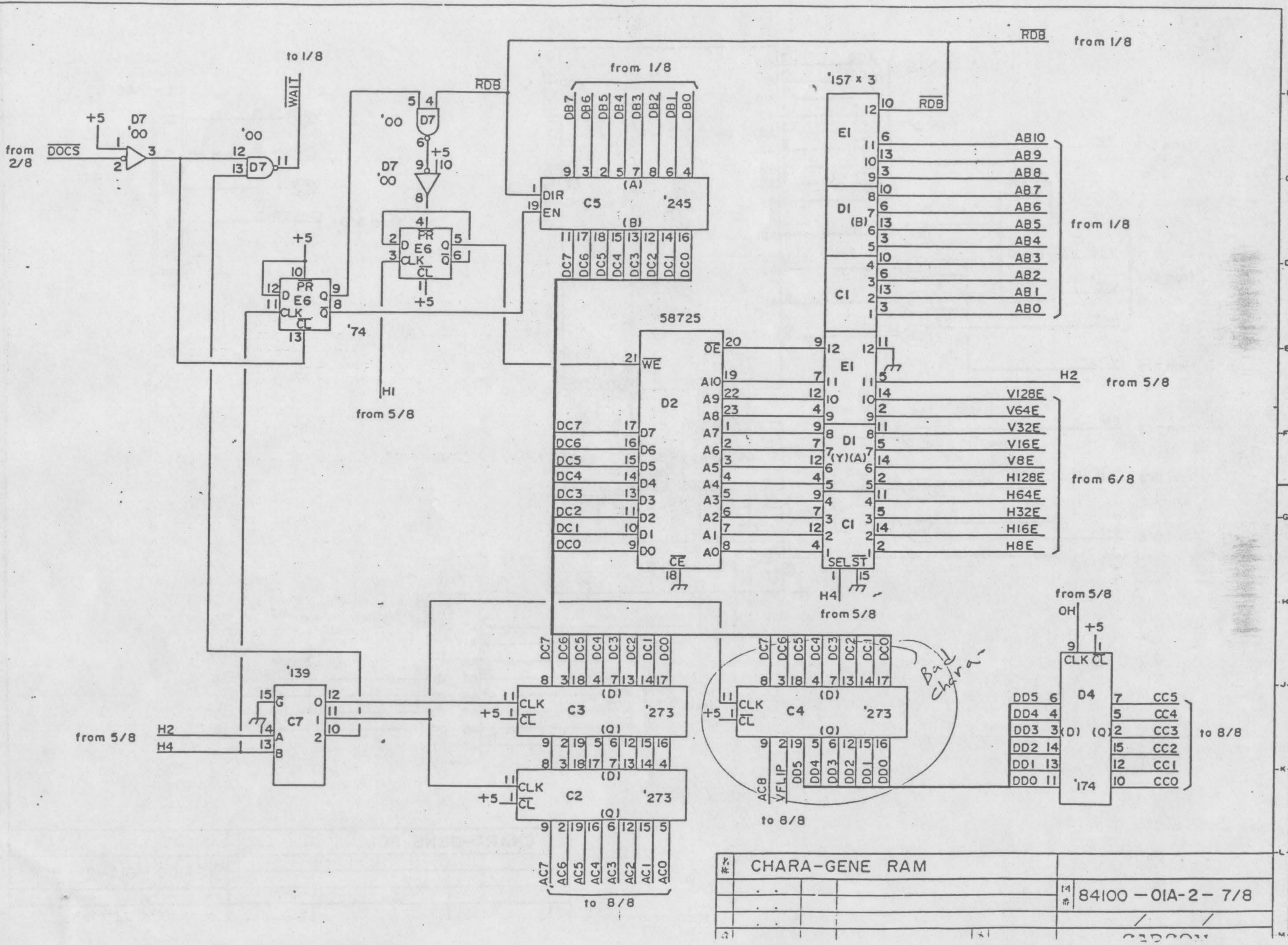

CHARA-GENE RAM	
Part No.	84100 - 01A-2 - 7/8
Rev.	
QTY	
Notes	

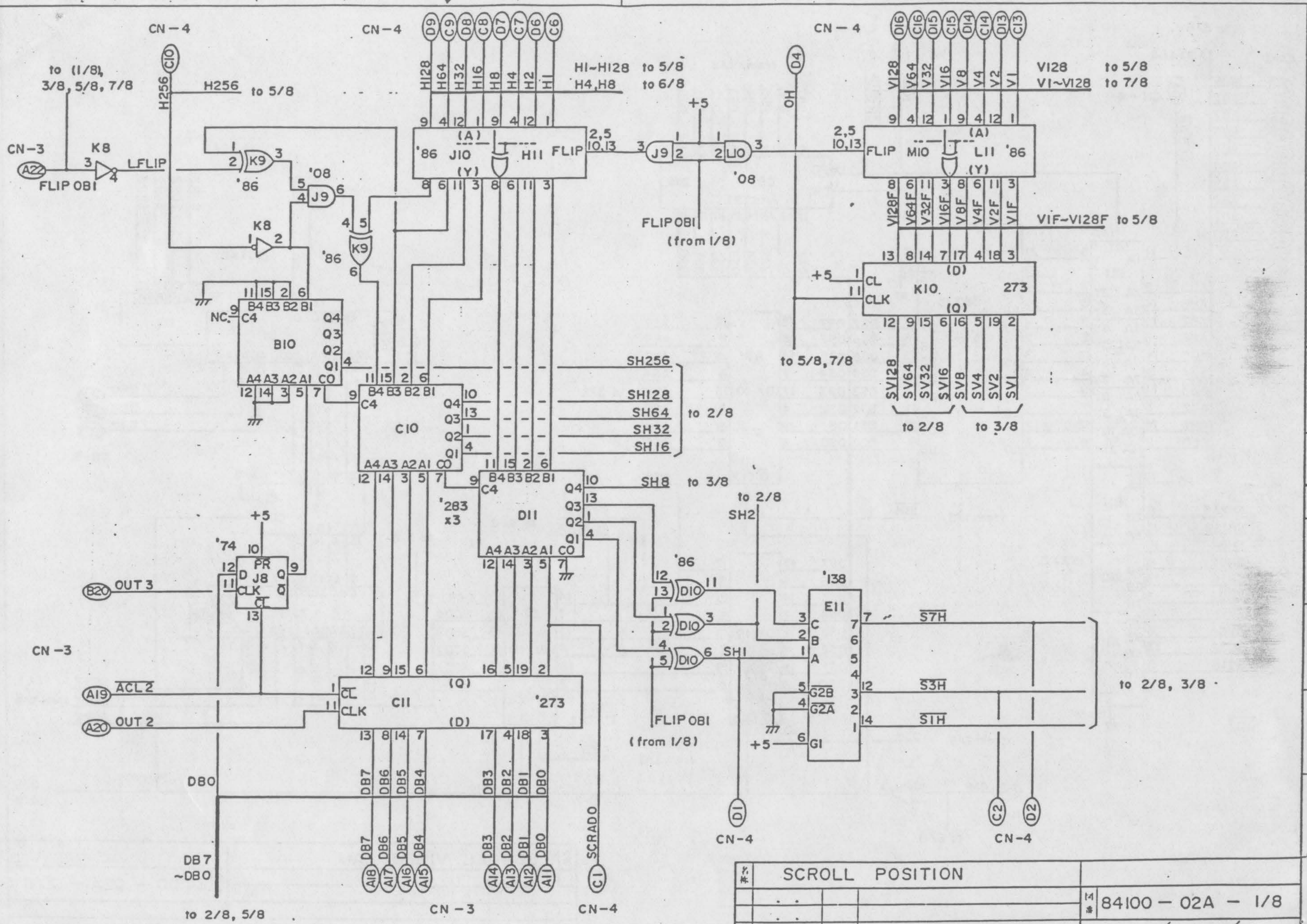

REV	SCROLL POSITION	
1		M# 84100 - 02A - 1/8
2		
3		
4		CAPCOM

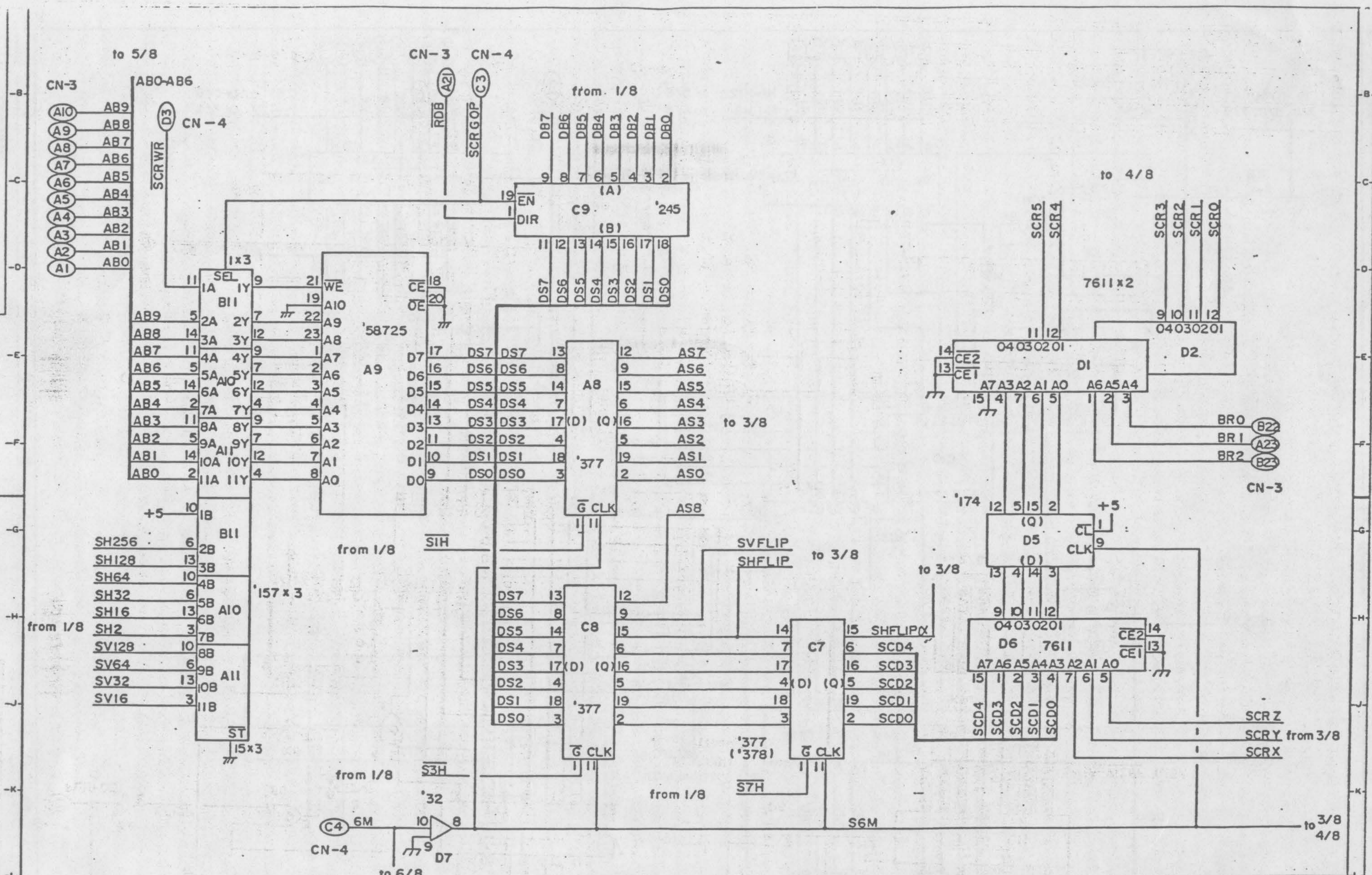

品名	SCROLL VIDEO RAM	図番	84100 - 02A - 2/8
仕様			
数量			
納入			
検出			
計			
			CAPCOM

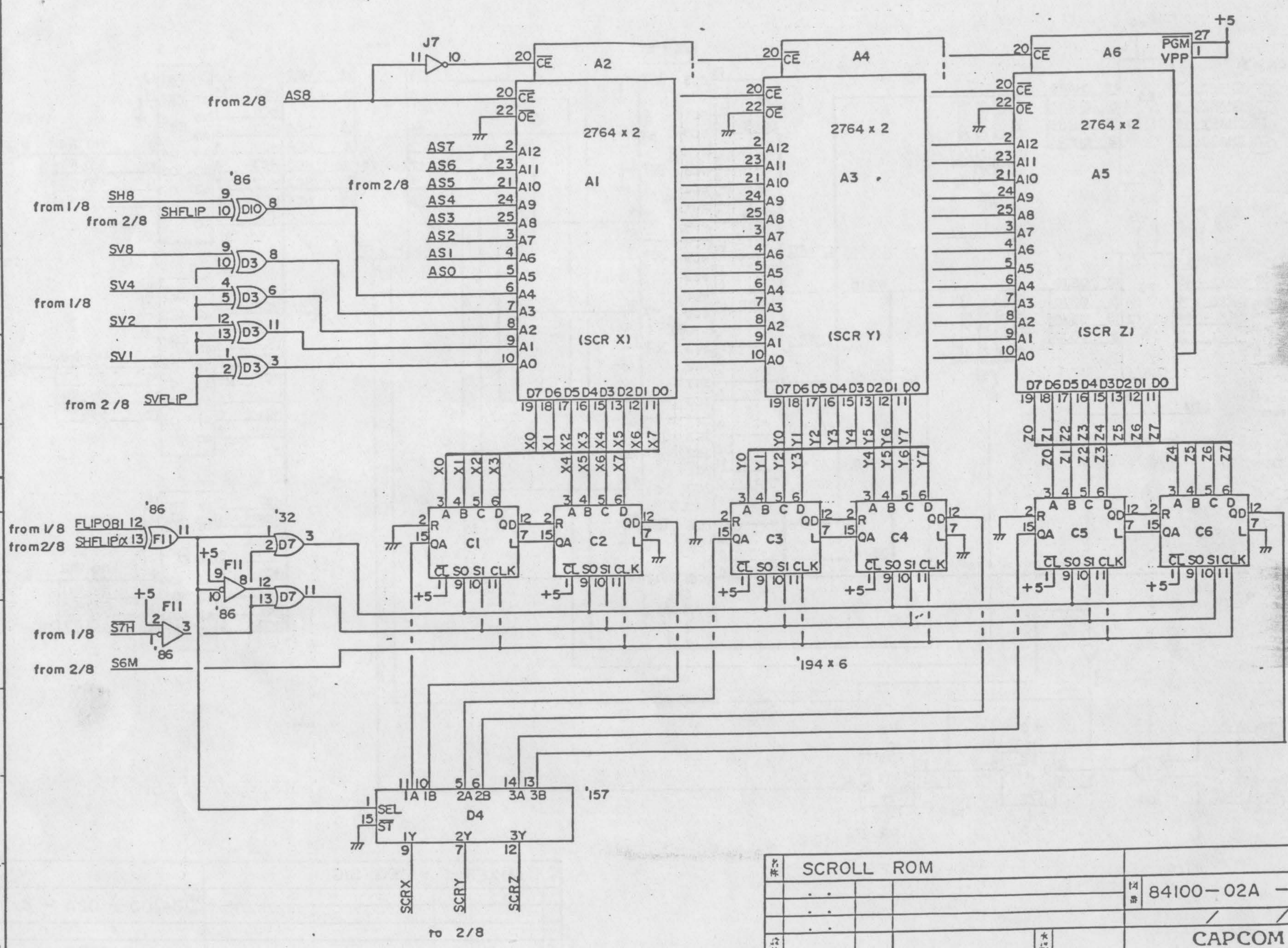

#	SCROLL ROM	Part No.
1		84100-02A - 3/8
2		
3		
4		
5		
6		
7		
8		
9		
10		
11		
12		
13		
14		
15		
16		

CAPCOM

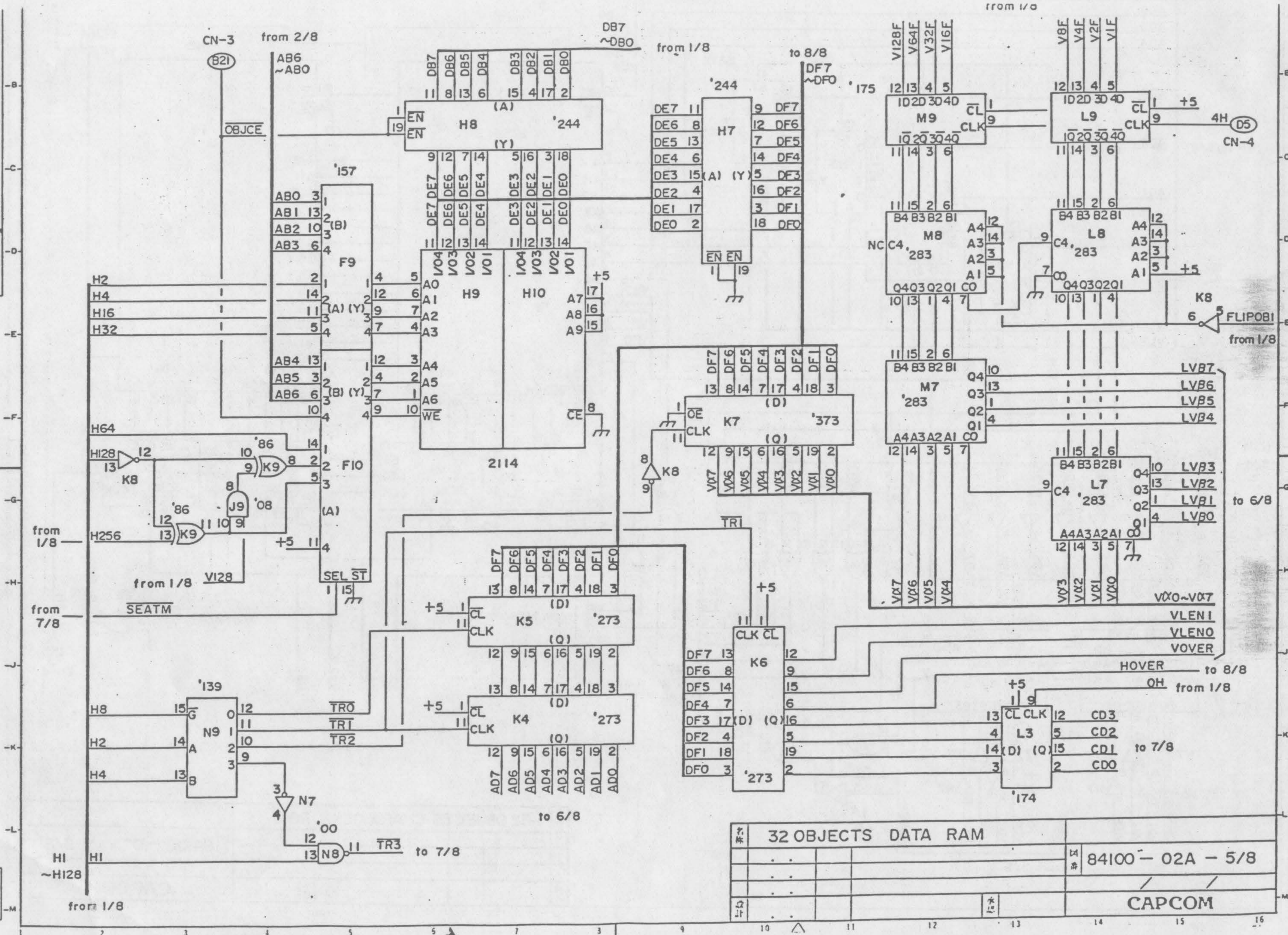

1	2	3	4	5	6	7	8	9	10	11	12	13	14	15	16
32 OBJECTS DATA RAM															
													84100-02A-5/8		
													CAPCOM		

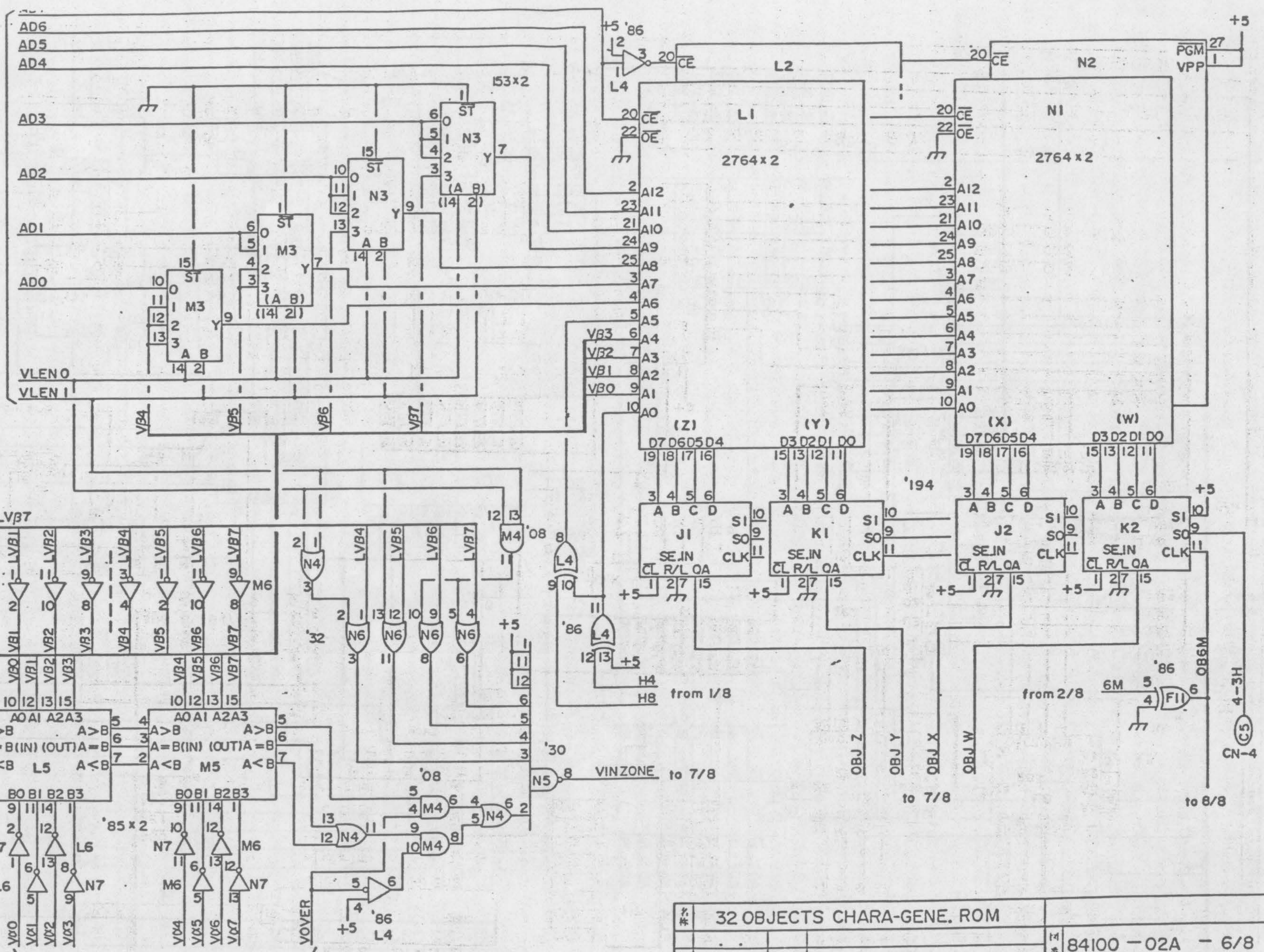

名称	32 OBJECTS CHARA-GENE. ROM	图号	84100-02A-6/8
规格		厂家	CAPCOM
数量		备注	

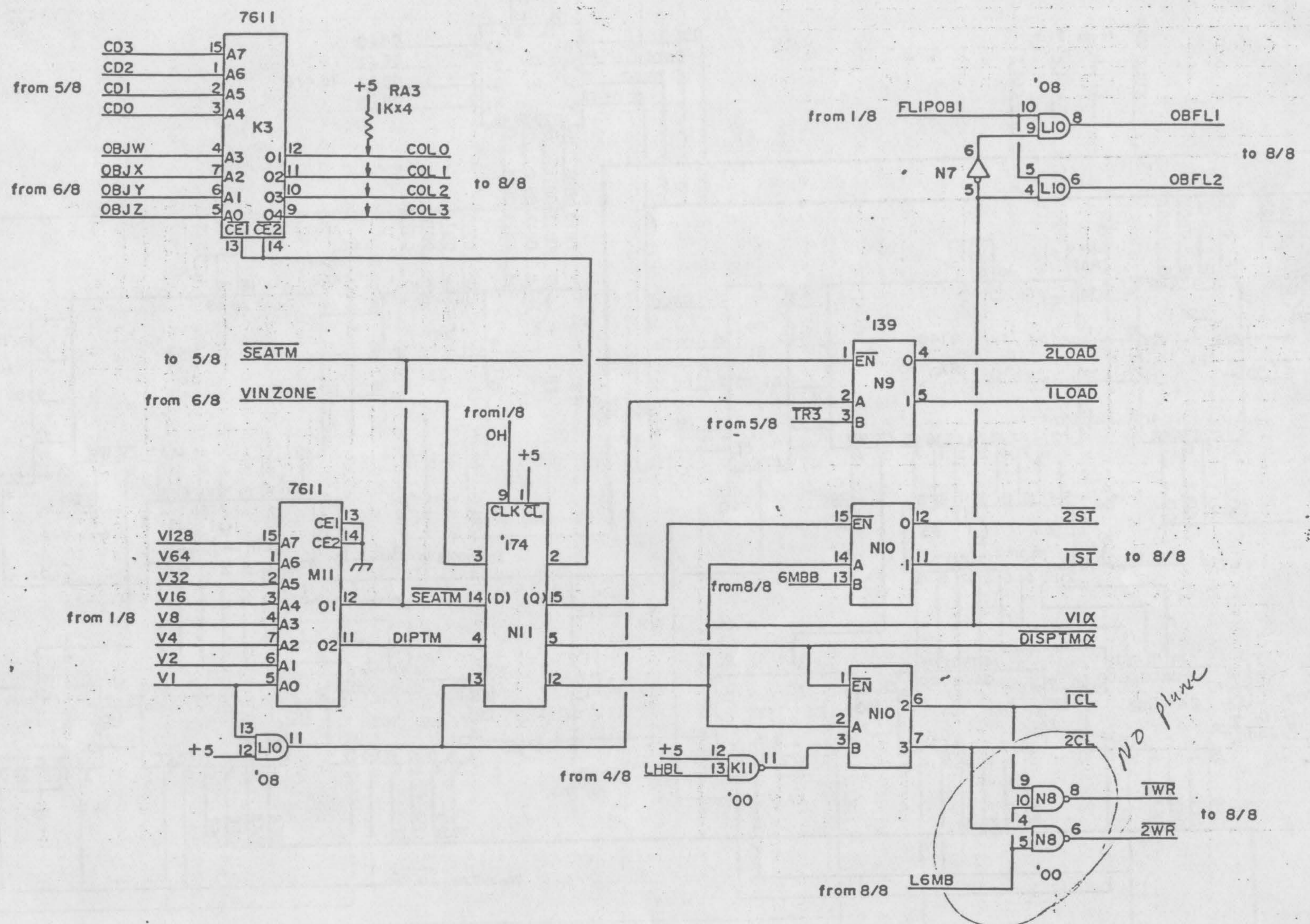

名称	OBJ	TIMING	SEC	图号
				84100-02A-7/8
				CAPCOM

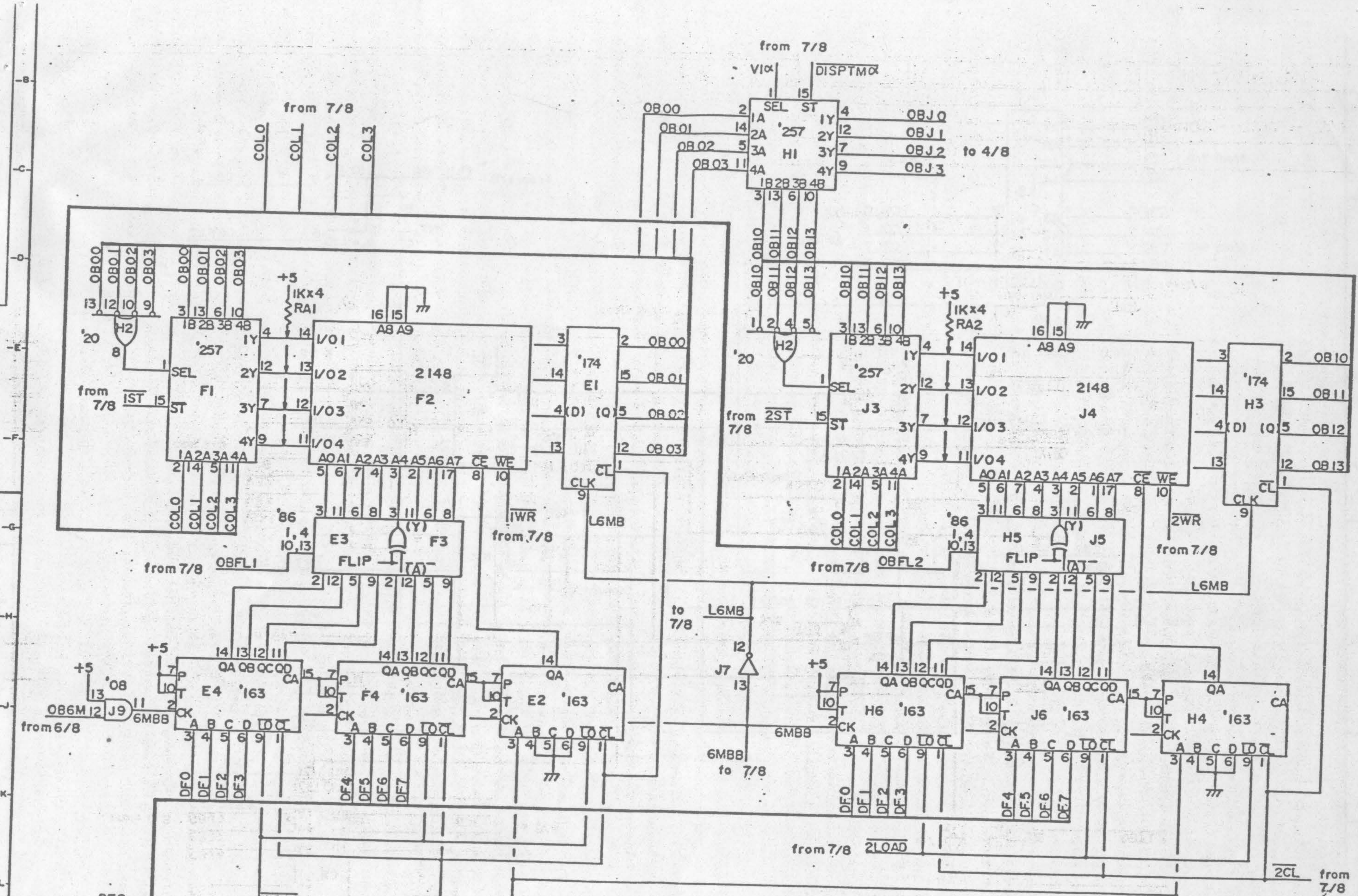

OBJ LINE BUFFER									
84100 - 02A - 8/8									
CAPCOM									